

### Main applications

- Industrial furnaces for heat treatments, metallurgy
- Sintering, Cementation, Nitriding Furnaces
- Furnaces for ceramics and precious metals
- Dryers
- Autoclaves
- Heating systems with single-phase and three-phase transformers ("symmetrical" and "asymmetrical")
- Heating systems with Molybdenum disilicon heating elements (MoSi<sub>2</sub>)
- Heating systems with Silicon Carbide resistors (SiC)
- Heating systems with graphite heating elements

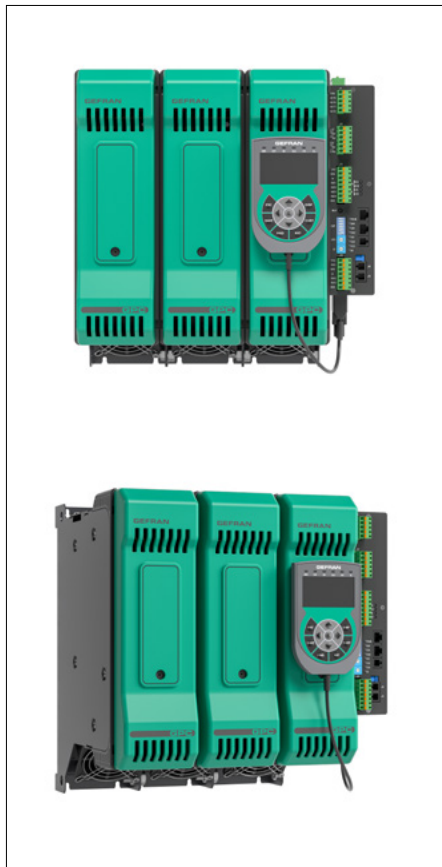

### Main features

- Single/two/three-phase Current capacities from 40 A up to 600 A
- Operating voltages 480 Vac, 600 Vac and 690 Vac
- Firing mode configurable in "Zero crossing" ( Fixed Cycle, Burst Firing, Half Single Cycle ) and "Phase angle"
- Three analogue control inputs configurable in Volt, mA, potentiometer and digital "PWM" for power % control
- 4 digital inputs, 3 of which can be configured as "PWM" input for power % control
- Three settable retransmissions analogue outputs
- Optional inputs from external TA and TV
- Soft\_Start and RMS and peak current limits
- Feedback V, V<sub>2</sub>, I, I<sub>2</sub>, P
- Total and partial interrupted load alarms with Relay outputs
- Built-in fuses
- Temperature sensors on Power terminals and cooling air inlet
- Fieldbus: PROFINET, Profibus, Modbus TCP/RTU, Ethernet IP, EtherCAT, Canopen
- Configuration keyboard and monitor
- PC configuration tool with configuration wizard (SMART)
- CE, UL certifications and SCCR UL 508 100KA approvals

### PROFILE

The **GPC** series of electric power controllers allows great application flexibility for all current sizes, from 40 Amperes up to 600 Amperes, in single-phase, two-phase and three-phase configurations.

They are ideal for accurate, stable temperature control in industrial heating systems.

Advanced load control functions make it possible to manage linear resistors with a low thermal coefficient, non-linear resistors with a high thermal coefficient, infrared lamps, and single-phase and three-phase symmetrical and asymmetrical transformers.

Compact mechanics, ease of cabling with front connections and plug-in connectors and easy configuration methods ensure considerable savings in terms of panel space and installation time, without sacrificing robustness and considerable diagnostic capacity.

### UNIVERSAL COMMANDS

All GPC models can be controlled in different ways, so that they can be adapted to the various control solutions and architectures found in the field. There are three analog inputs, widely configurable, so as to allow not only the control of two-phase and three-phase devices with a single command, but also the single and independent control of each available module. The GPC can also be controlled with digital ON/OFF controls

or in PWM mode, with potentiometers, with one of the various Fieldbuses that complete the options of this range.

### CONTROL FUNCTIONS

Flexibility in the control of electrical loads, even very different from each other, is guaranteed by a vast choice of trigger types, freely configurable on all models.

You can choose "zero crossing" mode with fixed cycle times or "Burst firing" mode with optimized cycle times, for linear loads and systems with high thermal inertia, or opt for faster firing modes, such as the "half single cycle", ideal for managing medium wave IR lamps, or choose "phase angle control" for SWIR lamps, non-linear heating elements such as "silicon carbide", "molybdenum disilicon" and single-phase and three-phase transformer primaries. Whichever control configuration is chosen, GPC models are able to deliver the desired electrical power with precision, from 0% to 100%.

Control is completed by soft-start functionalities at power on, current limits which can be set to both peak and RMS values, and closed loop feedback algorithms for voltage, current and power guaranteeing the stability of the supply even in the presence of variations and perturbations of the nominal values.

Some functions of the GPC range are designed to solve specific applications and problems:

In the case of systems with three-phase transformers, any breakage of a three-phase load branch is managed by the Controller, which provides an immediate alarm signal while at the same time continuing to supply energy to the two intact phases, allowing the process to remain in a holding condition.

In heat treatments with non-linear resistors such as silicon carbide, it is possible to bring the heating elements to temperature with "phase angle" control and active current limits, and then automatically switch to "zero crossing" control when the elements are at temperature and no more current peaks occur, only to return to "phase angle" control automatically if further peaks should reoccur.

In industrial furnaces, three-phase transformers are very often used, which can be made with symmetrical or asymmetrical primary/secondary connections. GPC controllers can manage both types indiscriminately without any impact on performance.

Auxiliary inputs of voltage ( V load ) and current ( external CT ) permit correct management of all applications where cable length and transformer type require precise measurement of voltage and current exactly on the load, regardless of other plant engineering factors.

In the case of several loads managed by several controllers, there is a need to rationalise and synchronise the power outputs of the individual controllers so as to reduce the current/energy peaks supplied instantly or, in some cases, limit the total value to a maximum that can be set. These functions are performed by a special external controller, the GSLM, capable of managing up to 64 controllers and configurable via VNC.

## DIAGNOSTICS, PREVENTIVE MAINTENANCE AND ALARMS

Great care has been taken in the development of diagnostic, preventive maintenance and alarm functions that can be associated with current, voltage, power and operating temperatures. The process and the power controller are continuously monitored.

### Current values

Total or partial interrupted load alarm, with self-learning of the alarm thresholds  
SCR short circuit alarm  
Load short circuit alarm or overcurrent  
Internal fuse breaking alarm

### Voltage values

No line voltage alarm  
Unbalanced three-phase line alarm  
Indication of incorrect phase rotation in three-phase systems (without stopping operation of the Controller)

### Temperature values

Exclusive continuous temperature measurement of all power terminals with loosened terminal alarm.  
Continuous monitoring of the internal temperature of the power module with automatic disconnection in the event of over-temperature, with alarm signal.  
Fan output temperature measurement for electrical panel cooling system efficiency diagnostics.  
Alarm due to lack of fan power supply

The GF\_express configuration SW also offers an extensive list of additional diagnostic conditions such as the storage of alarm states, for immediate and easy analysis in the event of an anomaly.

## CONFIGURATIONS

Various levels of GPC configuration have been designed with the aim of making initial start-up operations as simple and intuitive as possible. The GF\_eXpress configuration SW (freely downloadable from the website [www.gefran.com](http://www.gefran.com)) contains a section entitled "Smart Configuration" which, through a few steps with questions concerning the application, configures the Controller without needing to know its parameters and their meaning. At the end of the procedure (average duration 5 minutes) the controller is ready to pilot the load. A second level offers "Wizard" pages showing the main parameters divided by topics, with part of the parameters monitor always active.

You can create and save entire parameter recipes and easily copy them to other devices with GF-express in addition to monitoring parameters and viewing them in a graph with the oscilloscope function.

The GPC Controllers can be equipped with a portable programming terminal, GPC-OP, powered by the Controller, which permits monitoring of the process variables and, if necessary, modification of the configurations via password.

## FIELDBUS

A Modbus RTU port is always available, for both connections with the configuration tool and with HMI or PLC devices equipped with Modbus Master communication.

An extensive range of Fieldbus options let you add GPC controllers in control architectures with the most popular PLC brands, allowing you to access any device variable with the standardized configuration files.

## MODELS

### General features:

Nominal voltage: 480 or 600V or 690V Nominal current: 40, 60, 100, 150, 200, 250, 300 Arms @ 40°C in continuous service. Nominal current: 400, 500, 600 Arms @ 50°C in continuous service.

### Isolation HV

Rated isolation voltage input/output: 4 000 Vac

## INPUTS

### Control analog input

N.3 inputs  
Voltage: 5Vdc, 10Vdc  
Current: 0...20mA, 4...20mA  
Potentiometer: From 1KΩ to 10KΩ (autofed by 5V from GPC)

### Digital inputs

N.4 inputs  
Range 5-30V max 7mA  
Input 1: configurable as PWM input control 0.03 ... 100Hz  
Inputs 2 and 3: configurable as PWM input control 0.03 ... 1Hz

### Voltage line range

Range: min 90Vac... max V\_nominal\_product (ref. product HW manual)  
Frequency: 50-60Hz

### Current load range:

Range: 0... 2\*I\_nominal\_product

### External current transformer inputs:

(optional)  
3 5Aac inputs(read f.s. settable with SW configuration parameter)

### Key HB:

HB alarm calibration ON or reset memory alarms.

## OUTPUTS

Power output, function mode:

**ZC** – Zero Crossing fixed cycle time

**BF** – Burst Firing

(Zero-crossing minimum optimize cycle time)

**HSC** – Half Single Cycle

(Zero-crossing corresponds to Burst Firing that

manages single semi-cycles of conduction or stop cycles.)

**PA** – Phase Angle

### Potentiometer power outputs:

5 Vdc, 30mA max

## ALARM OUTPUTS

2 Relays with changeover contact  
C-NO-NC (OUT9-10)  
4 Optional outputs - Relay, Digital (OUT 5-6-7-8)  
3 Optional analog outputs 10V/20mA 12 bit (OUT 5-6-7)

### Thermic Dissipation

GPC models dissipate thermic power based on load current:

$P_{dissipation} = I_{load\_Arms} * 1.3V (W)$

### Protective fuse

Installed inside product (optional)

## LED

N. 8 LEDs state indicator (Configurable)

### Modbus RS485 Serial (PORT1)

This lets you connect the GPC to a PLC or HMI via a simple RJ10 telephone wire by using an RS485 serial line with Modbus protocol. The Baud-Rate is configurable from 1200 Baud to 115000 Baud.

A pair of rotary-switches lets you quickly assign the node address.

A dip-switch lets you internally insert the line termination resistance.

### FieldBus Serial PORT2 (optional)

At the frontale of the device you can insert one of the following optional.

Modbus RTU, Modbus TCP, Profibus DP, PROFINET, CanOpen, Ethernet IP, EtherCAT.

### GFW/GPC-OP Serial Keypad

A DB9 connector lets you connect the GPC to the Gefran GFW/GPC-OP keypad (optional) for parameter configuration and device supervision.

### Installation notes:

- To assure maximum reliability, it is essential to install the unit correctly in the panel in order to guarantee adequate heat exchange between the heat sink and the room under natural convection conditions.

- Install the unit vertically (max 10° inclination from vertical axis).

- Vertical distance between unit and panel wall >100mm

- Use the high speed fuses specified in the catalog

- Applications with solid state power units must also include an automatic safety switch to cut out the load power line.

### Limits of use

- Dissipation of thermic power on the device with restraints on the ambient temperature of the installation.

- Equip the cabinet with an external air change or air-condition it, to put out dissipated power.

- Line transistor max. voltage and derivative limits, for which the solid state relay is equipped with inside safety devices (based on the models)

- Presence of load current dispersion range 5-20mA depending on model) in absence of thyristor conduction due to internal RC protections.

**Short circuit protection**

Products listed in table "UL508 SCCR FUSES TABLE" are suitable for use on a circuit capable of delivering not more than 100,000 A rms Symmetrical Amperes, 600 Volts maximum when protected by fuses. Use fuses only.

According to UL508, test at 100.000A were carried out with class J fuses rated xxxA (refer to table "SCCR fuse protection table" to details of the current size fuses for the fuse).

After a shortcircuit the functioning of the device is not guaranteed.

To guarantee the functioning of the device after the short circuit, it is recommend the use of extra rapid fuses as in table "EXTRARAPID FUSES".

**ATTENTION:** The opening of the branch-circuit protective device may be an indication that a fault has been interrupted. To reduce the risk of fire or electric shock, current-carrying parts and other components of the device should be examined and replaced if damaged. If burnout of the device occurs, the complete device must be replaced or equivalent.

**DERATING KURVEN**

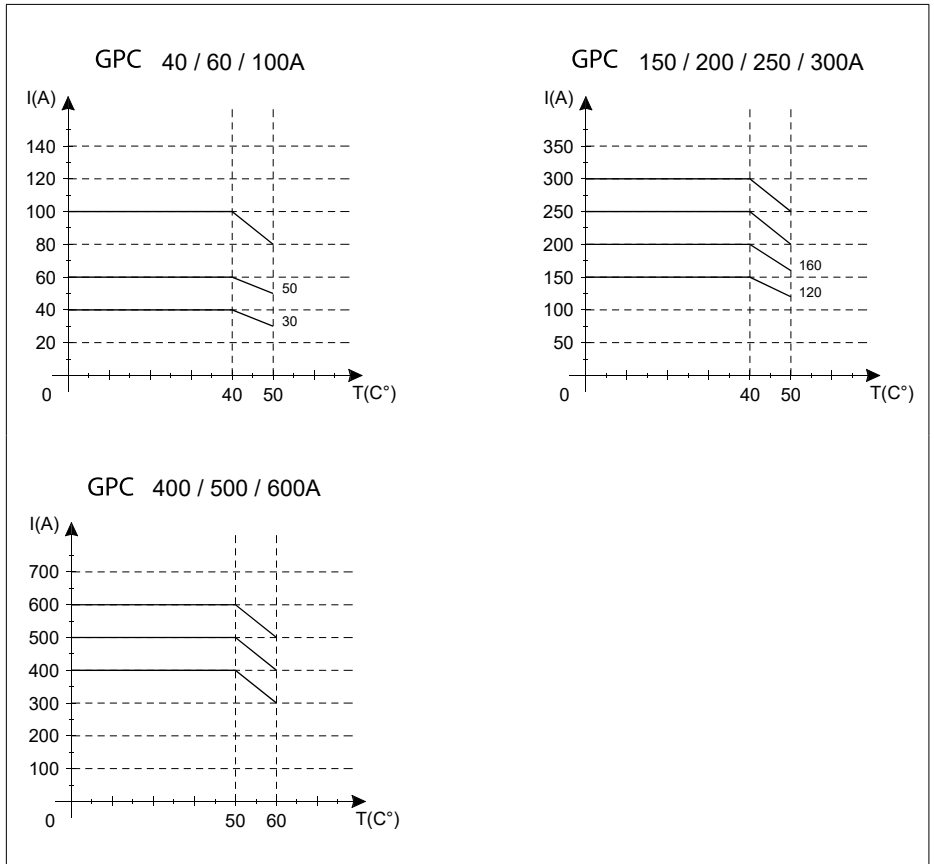

**Trigger modes**

The GPC provides the following power control modes:

- modulation via variation of phase angle: PA modality
- modulation via variation of number of conduction cycles with "zero crossing" trigger: ZC, BF, HSC modality.

**PA - Phase angle**

This mode manages power on the load by modulating load phase angle

- ex: if power to be transferred to the load is 100%,  $\theta = 180^\circ$
- ex: if power to be transferred to the load is 50%,  $\theta = 90^\circ$

**FUNCTION MODE**

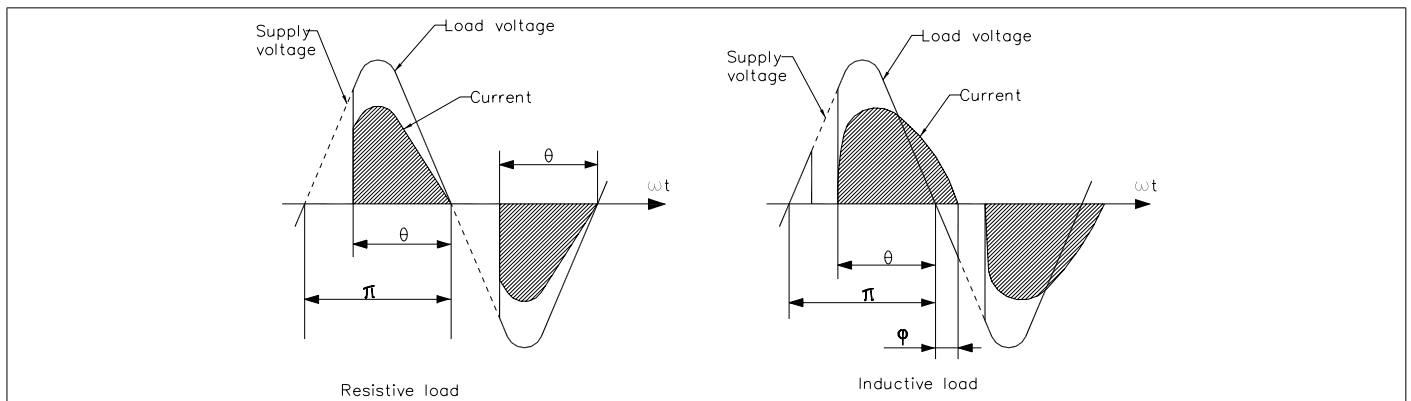

**Zero Crossing mode**

This function eliminates EMC noise. This mode controls power on the load via a series of conduction ON and non conduction OFF cycles.

**ZC** - Zero Crossing constant cycle time ( $T_c \geq 1$  sec, settable from 1 to 200 sec) Cycle time is divided into a series of conduction and non conduction cycles in proportion to the power value to be transferred to the load.

For example, if  $T_c = 10$ sec, if the power value is 20% there is conduction for 2 sec (100 conduction cycles @ 50Hz) and non conduction for 8 sec (400 non conduction cycles @ 50Hz).

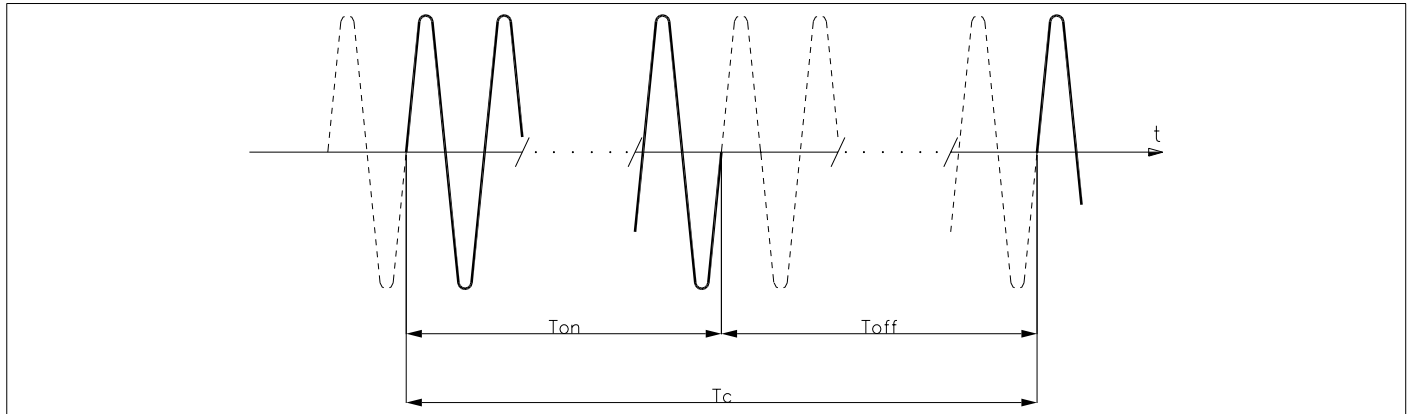

**BF - Burst Firing, Zero Crossing variable cycle time.**

This mode controls power on the load via a series of conduction ON and non conduction OFF cycles. The ratio of the number of ON cycles to OFF cycles is proportional to the power value to be supplied to the load.

The CT repeat period is kept to a minimum for each power value (whereas in ZC mode the period is always fixed and not optimized)

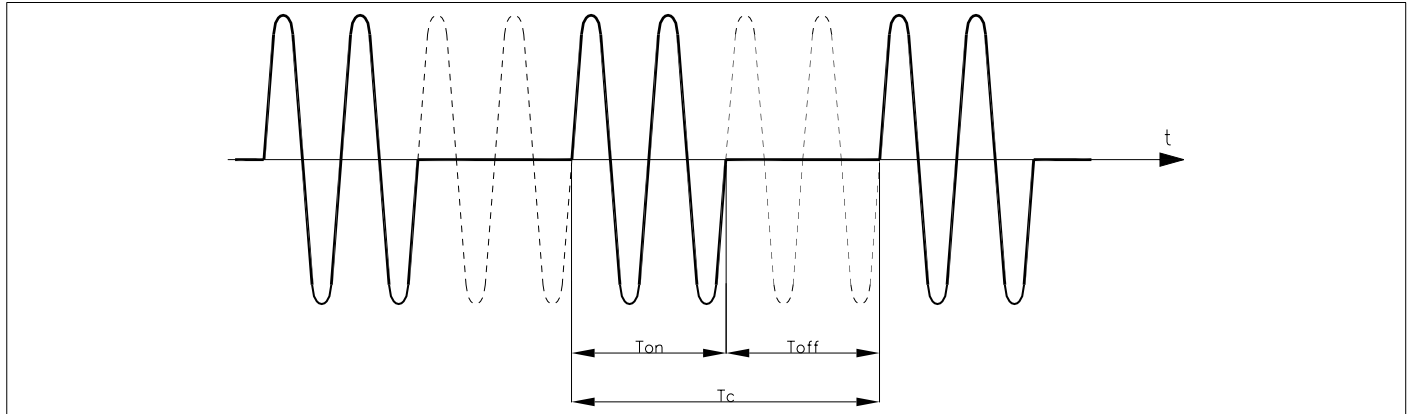

Example of operation in BF mode with power at 50%.

A parameter defines the minimum number of conduction cycles settable (from 1 to 10). In the example, this parameter = 2.

**HSC - Half single cycle**

This mode corresponds to Burst Firing that manages Semi-cycles of on and off.

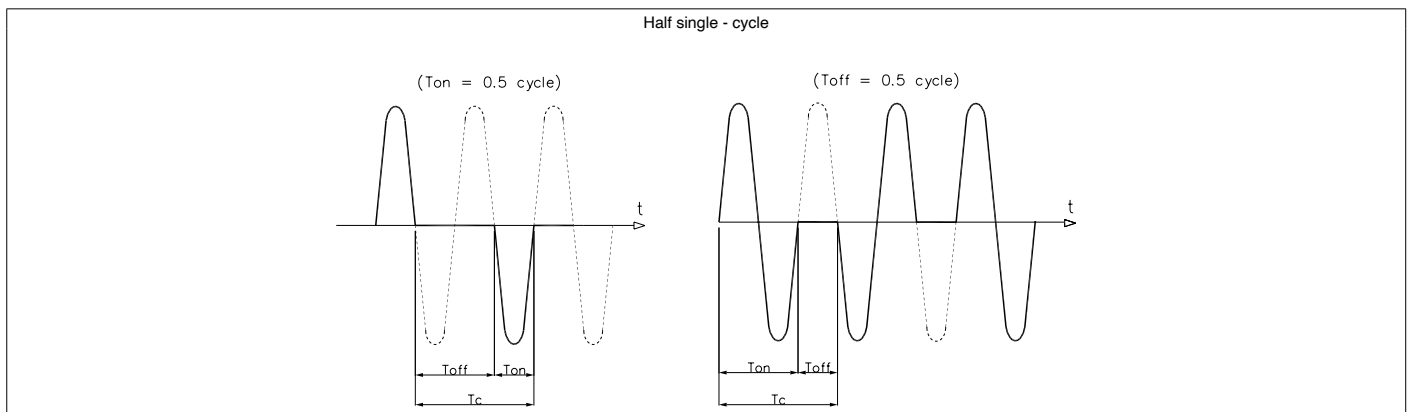

Ex function in modality HSC with power to 33 and 66%.

### Softstart at power-on

This type of start can be enabled in either phase control or pulse train mode. With phase control, the increment of firing angle  $\theta$  stops at the corresponding power value to be transferred to the load.

The control of maximum current spike can be enabled during the ramp phase (this is useful in case of short circuit on the load or loads with other temperature coefficients to automatically adjust the start time of the load).

The ramp is automatically re-enabled if the GPC remains off for a (settable) time.

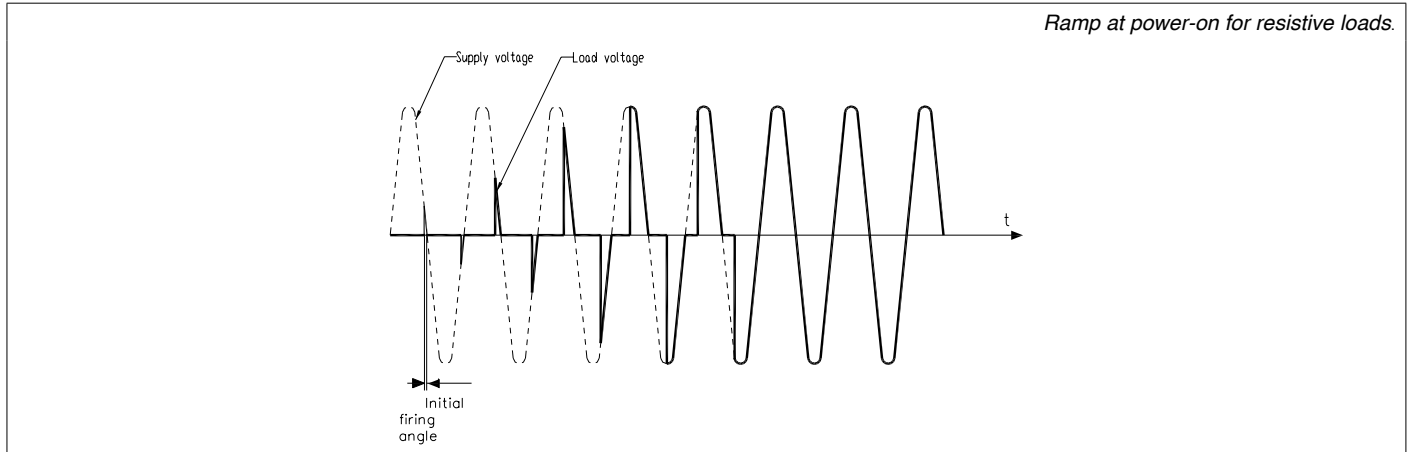

**DT** - "Delay triggering" of first cycle (only for control modes ZC, BF) Settable from  $0^\circ$  to  $90^\circ$ .

Useful for inductive loads (transformer primaries) to prevent current spike that could in certain cases trip the high-speed fuses that protect the SCRs.

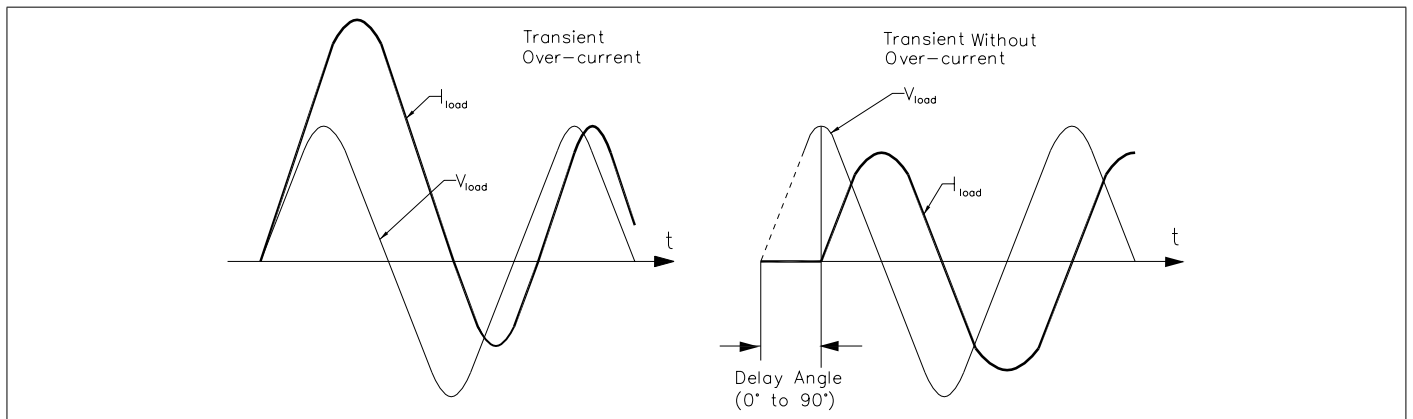

# DESCRIPTION OF CONNECTIONS

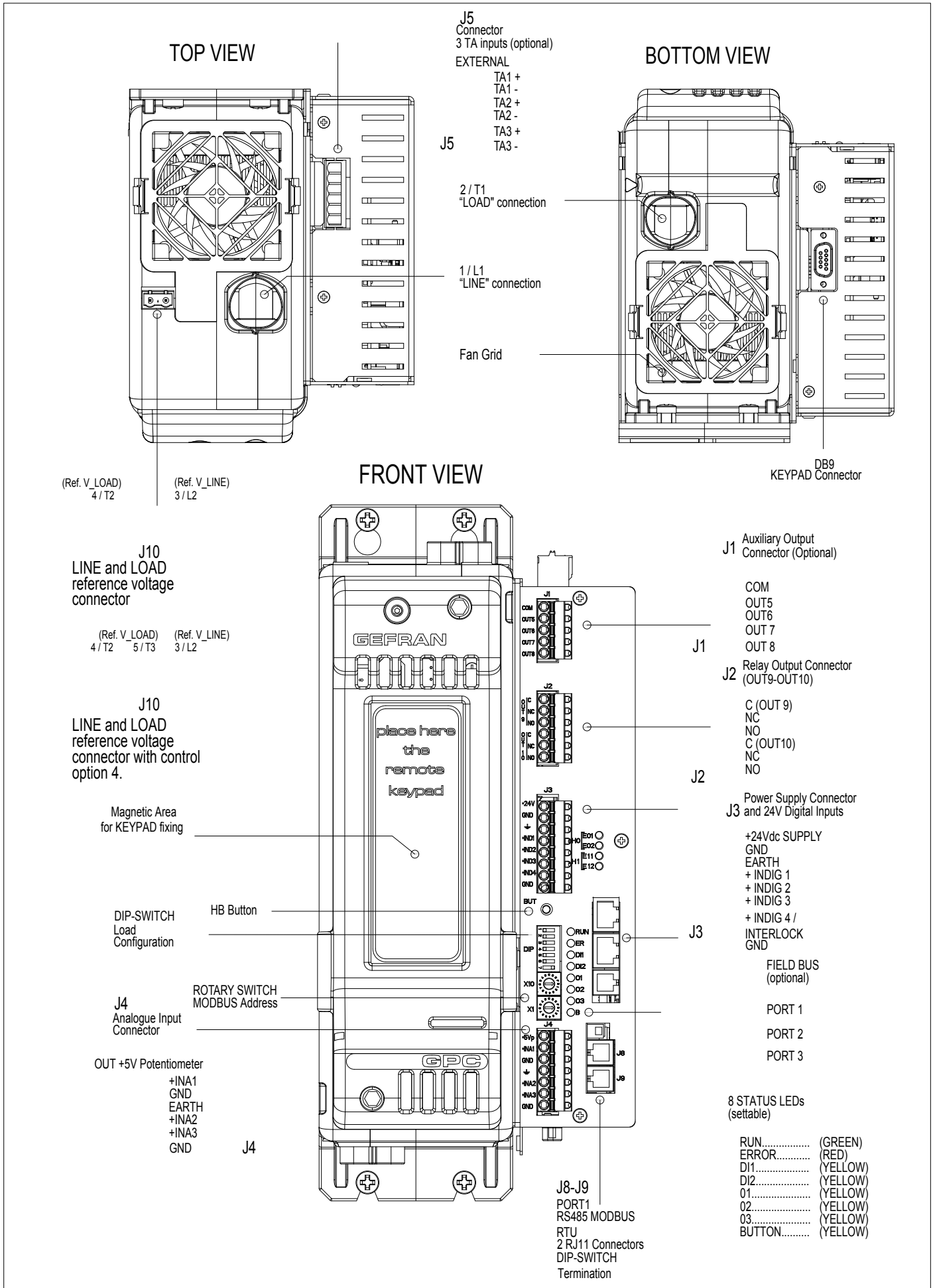

# DESCRIPTION OF CONNECTIONS (for models GPC 400-600A)

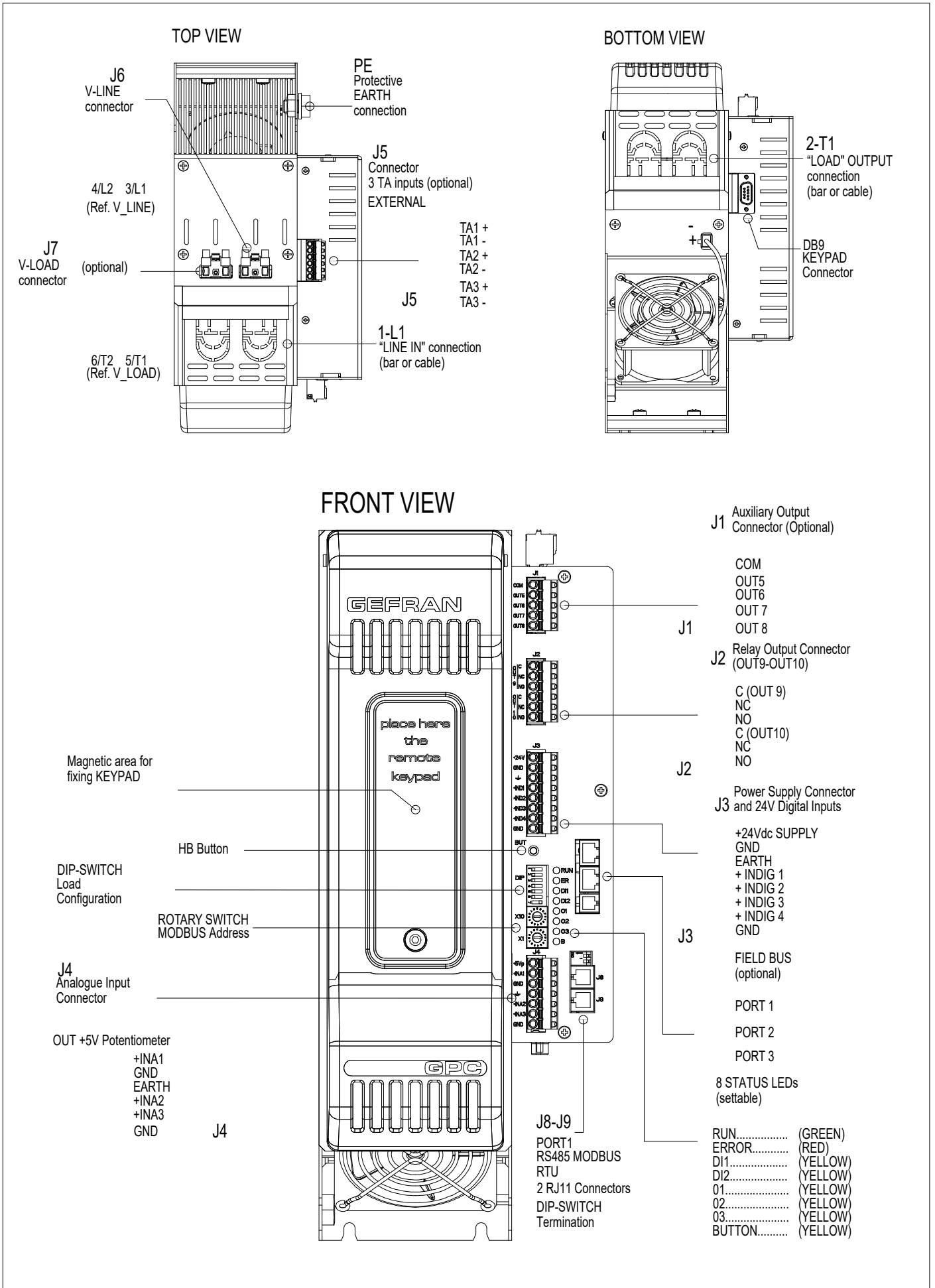

# DIMENSIONS (models GPC 40-300A)

## GPC MASTER

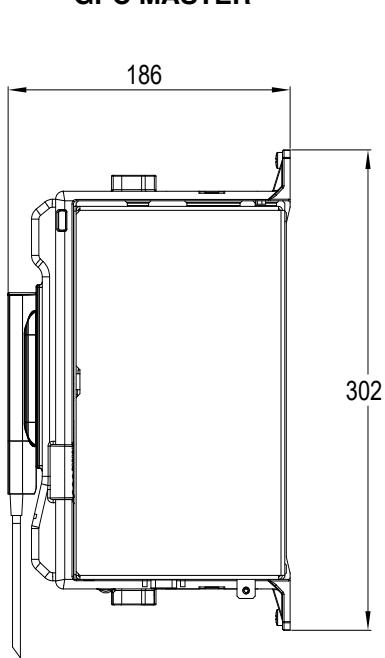

SIDE VIEW  
with KEYPAD

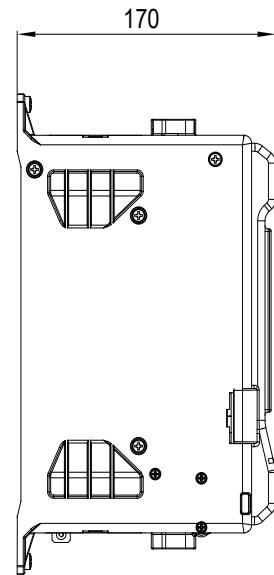
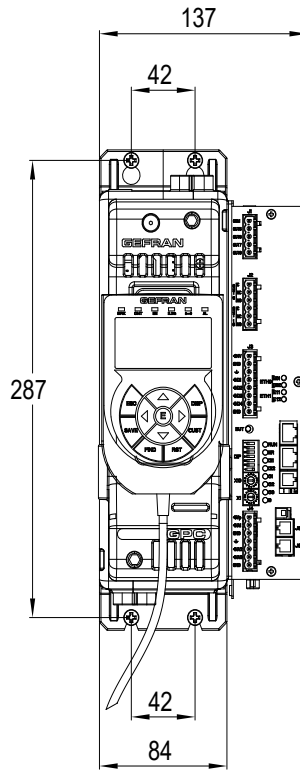

SIDE VIEW without  
KEYPAD

## GPC DUAL-PHASE (Master + 1 Expansion)

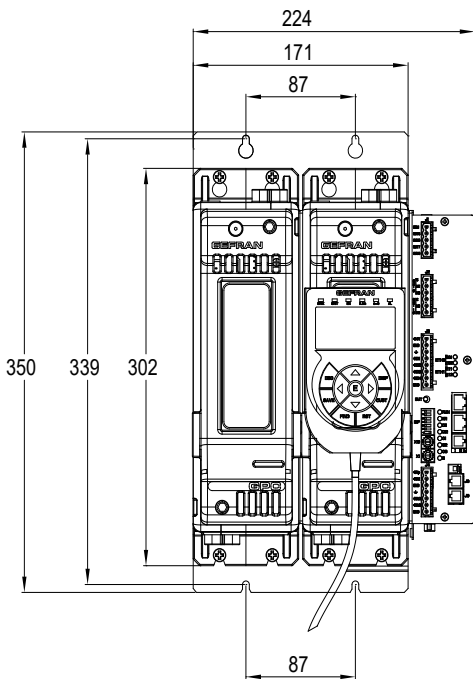

## GPC THREE-PHASE (Master + 2 Expansions)

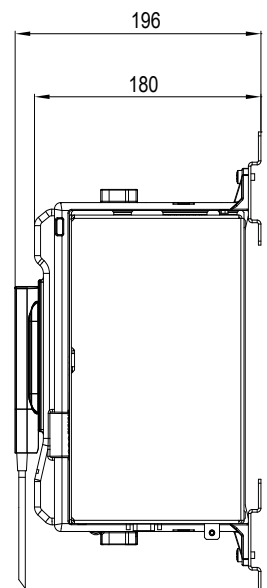
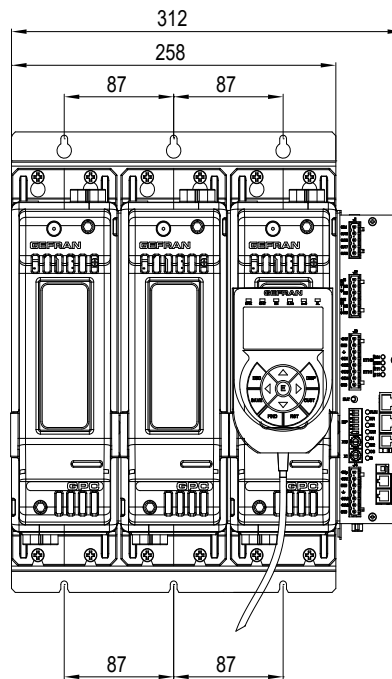



# DIMENSIONS (models GPC 400-600A)

## GPC MASTER

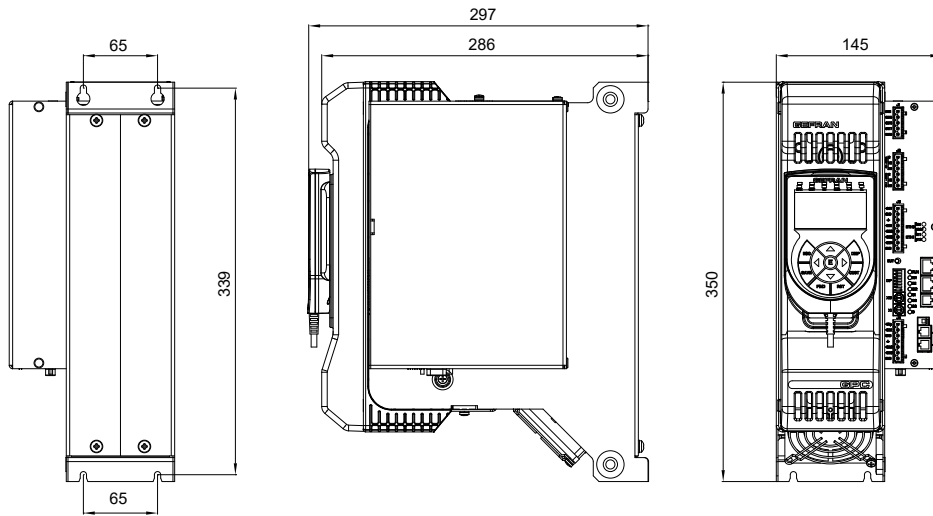

## GPC DUAL-PHASE

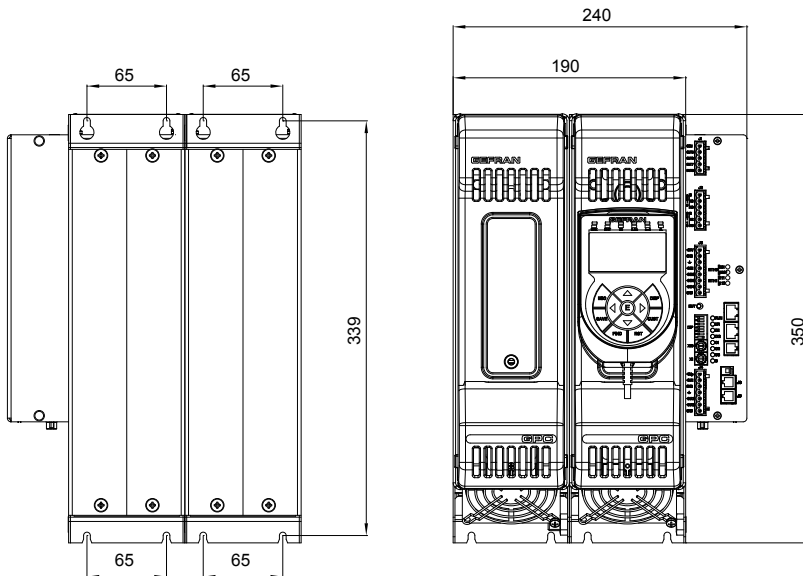

## GPC THREE-PHASE

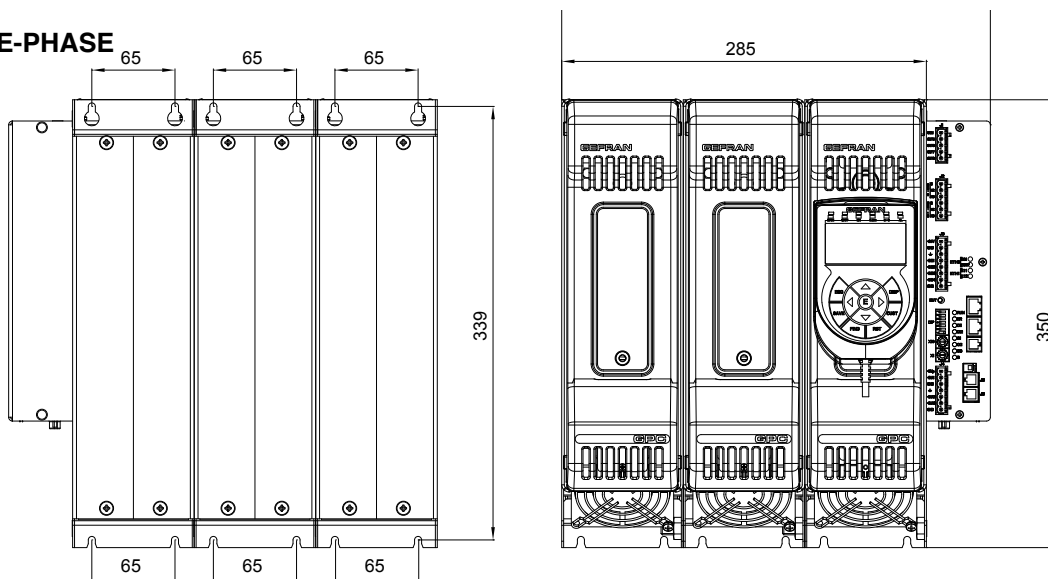

## TEMPLATE DIMENSIONS (models GPC 40-300A)

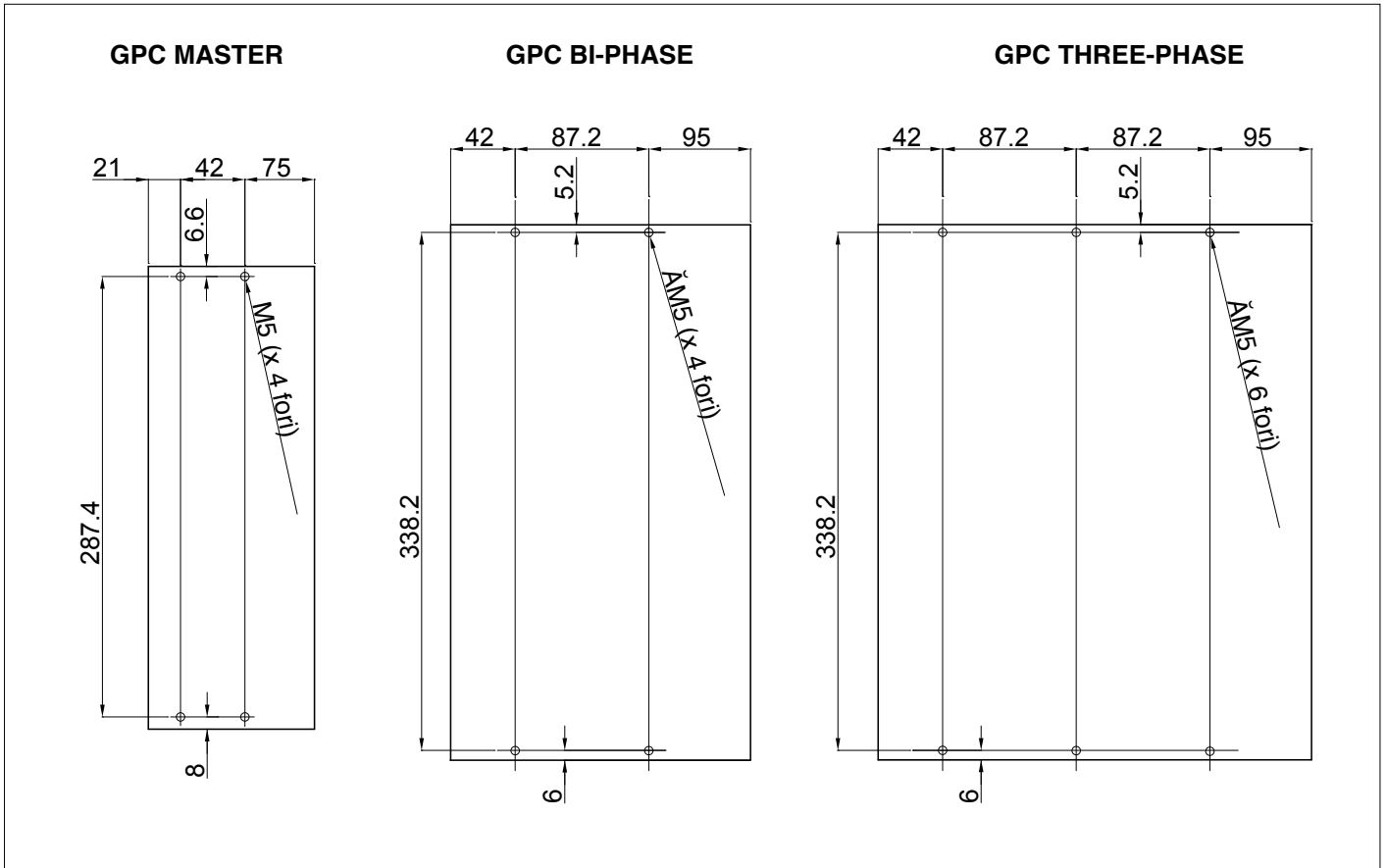

Fastening may be done with (5MA). All dimensions are expressed in mm.

## TEMPLATE DIMENSIONS (models GPC 400-600A)

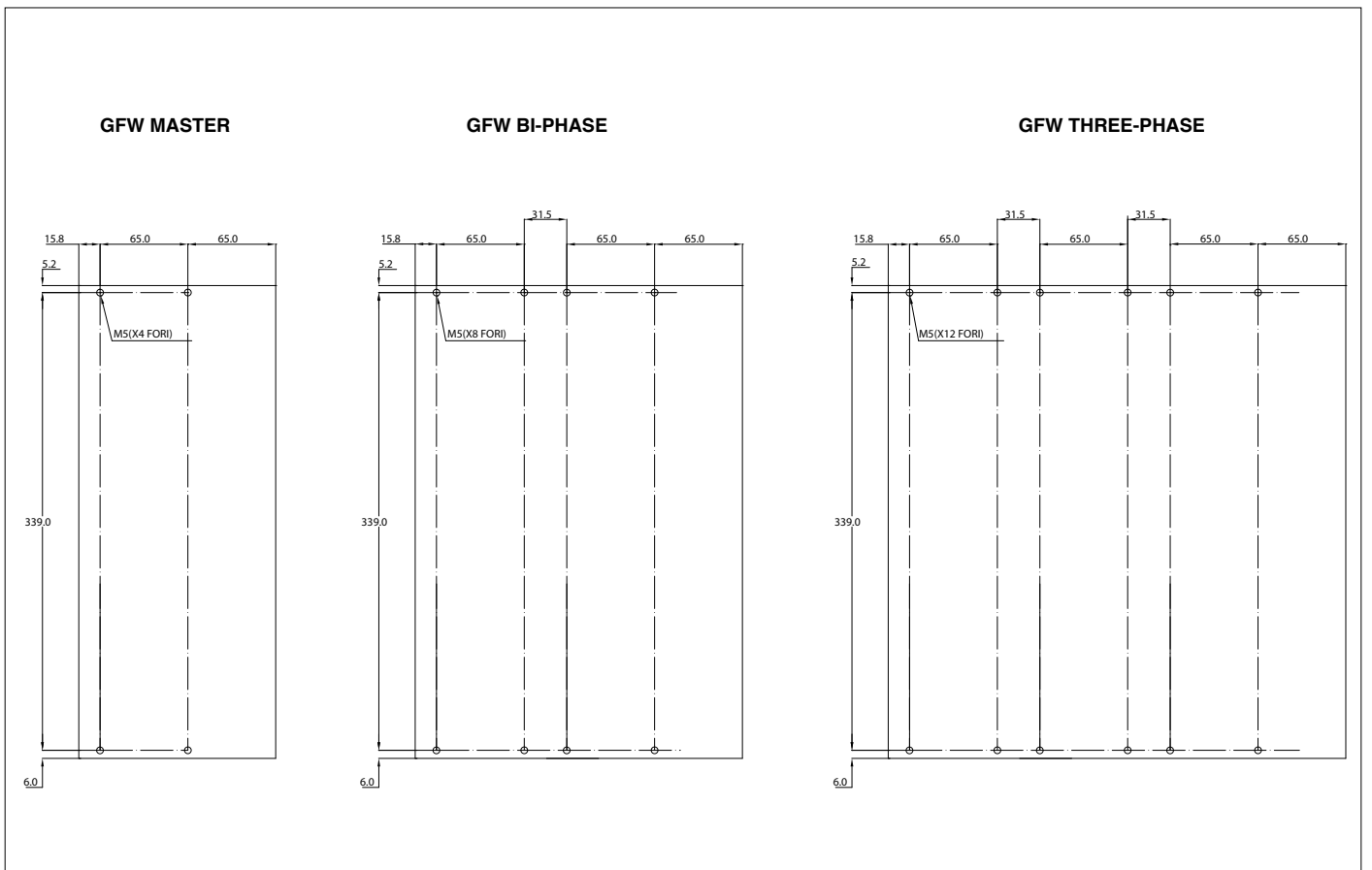

# TECHNICAL DATA

## General features

Category of use:  
AC51, AC55b, AC56a

## Load type:

**AC51** resistive or low-inductance loads  
**AC55b** short-wave infrared lamp (SWIR)  
**AC56a** transformers, resistive loads with high temperature coefficient.

## Trigger mode:

**PA** - load control via adjustment of firing phase angle  
**ZC** - Zero Crossing with constant cycle time (settable in range 1-200sec)  
**BF** - Burst Firing with variable cycle time  
**HSC** - Half Single Cycle corresponds to Burst Firing that includes ON and OFF half-cycles.  
Useful for reducing flicker with shortwave IR loads (applied only to calibrate each time you change feedback mode).

## Nominal voltage:

480 Vac (max range 90-530 Vac)  
600 Vac (max range 90-660 Vac)  
690 Vac (max range 90-760 Vac)  
Nominal frequency: 50-60Hz

## Non-repetitive voltage:

1200Vp (models 480 Vac)  
1600Vp (models 600 Vac/690 Vac)

## Control analog input:

Voltage: 0...5Vdc, 0...10Vdc  
Ri = 90Kohm  
Current: 0...20mA, 4...20mA  
Ri = 250 ohm  
Potentiometer: from 1KΩ to 10KΩ (auto-fed by 5V by GPC)

## Digital inputs

Range 5-30V max 7mA  
Input 1: configurable as PWM input control 0.03 ... 100Hz  
Inputs 2 and 3: configurable as PWM input control 0.03 ... 1Hz  
Input 4: configured by default as Interlock function

## Voltage line range

Range: min 90Vac... max V\_nominal\_product (ref. product HW manual)  
Frequency: 50-60Hz  
Accuracy: 1% f.s with neutral connected, 2% f.s. without neutral connected

## Voltage load range:

Accuracy: 1% f.s with load voltage measurement option (VLOAD option)  
Accuracy: 2% f.s without option VLOAD

## Current load range

measures RMS value  
Accuracy: 2% f.s at room temperature of

25°C. Sampling time: 0.25msec

## Measurement of external current transformer:

(Optional)  
Input f.s.: 5A rms  
Input impedance: 16 mΩ  
Accuracy: 2% f.s. at room temperature of 25°C  
Sampling time: 0.25msec  
SW parameter to set current transformer transformation ratio in range 1...655 (allows measurement of current to secondary up to 3275A).

## HB alarm output (optional)

The HB function detects partial or total load interruption.  
The control measures load current by means of an internal device.  
The current limit value is set via an automatic procedure activated with the HB button located near the upper connector.  
The alarm output is obtained by means of outputs OUT 9-10 (or OUT 5-8).

## RS485 serial (PORT1)

Double RJ10 connector  
RTU RS485 Modbus Protocol  
Baud-Rate configurable from 1200 Baud to 115000 Baud  
Pair of rotary-switches for node address.

Dip-switch for insertion of line termination resistance. Isolation 1500V

## Field bus (PORT2)

Protocol:  
Modbus RTU\_\_\_\_\_115Kbps  
CANopen 10K...1Mbps  
Profibus DP\_\_\_\_\_9,6...12Mbps  
Ethernet IP/Modbus TCP 10/100Mbps  
EtherCAT 10/100Mbps  
PROFINET 10/100Mbps

## OUTPUTS

### Isolation HV

Rated isolation voltage input/output:  
4000 Vac

### GPC 40

Nominal current 40 Arms @ 40°C in continuous service  
Non-repetitive overcurrent t=10ms: 1400 A  
I<sup>2</sup>t for blowout: 10000 A<sup>2</sup>s  
dV/dt critical: 1000 V/μs

### GPC 60

Nominal current 60 Arms @ 40°C in continuous service  
Non-repetitive overcurrent t=10ms: 1500 A  
I<sup>2</sup>t per fusione: 12000 A<sup>2</sup>s

dV/dt critica: 1000V/μs

### GPC 100

Nominal current 100 Arms @ 40°C in continuous service  
Non-repetitive overcurrent t=10ms: 1900 A  
I<sup>2</sup>t for blowout: 18000 A<sup>2</sup>s  
dV/dt critical: 1000V/μs  
SCCR: 100KA 600V UL508 conformant

### GPC 150

Nominal current 150 Arms @ 40°C in continuous service.  
Non-repetitive overcurrent t=10ms: 5000 A  
I<sup>2</sup>t for blowout: 125000 A<sup>2</sup>s  
dV/dt critical: 1000V/μs

### GPC 200

Nominal current 200 Arms @ 40°C in continuous service.  
Non-repetitive overcurrent t=10ms: 8000 A  
I<sup>2</sup>t for blowout: 320000 A<sup>2</sup>s  
dV/dt critical: 1000V/μs  
SCCR: 100KA 600V UL508 conformant

### GPC 250

Nominal current 250 Arms @ 40°C in continuous service.  
Non-repetitive overcurrent t=10ms: 8000 A  
I<sup>2</sup>t for blowout: 320000 A<sup>2</sup>s  
dV/dt critical: 1000V/μs  
SCCR: 100KA 600V UL508 conformant

### GPC 300

Nominal current 300 Arms @ 40°C in continuous service.  
Non-repetitive overcurrent t=10ms: 8000 A  
I<sup>2</sup>t for blowout: 320000 A<sup>2</sup>s  
dV/dt critical: 1000V/μs  
SCCR: 100KA 600V UL508 conformant

### GPC 400

Nominal current 400 Arms @ 50°C in continuous service.  
Non-repetitive overcurrent t=10ms: 8.000 A  
I<sup>2</sup>t for blowout: 1.125.000 A<sup>2</sup>s  
dV/dt critical: 1000V/μs  
SCCR: 100KA 600V UL508 conformant

### GPC 500

Nominal current 500 Arms @ 50°C in continuous service.  
Non-repetitive overcurrent t=10ms: 15.000 A  
I<sup>2</sup>t for blowout: 1.125.000 A<sup>2</sup>s  
dV/dt critical: 1000V/μs  
SCCR: 100KA 600V UL508 conformant

**GPC 600**

Nominal current 600 Arms @ 50°C in continuous service.

Non-repetitive overcurrent t=10ms:  
15.000 A

I²t for blowout: 1.125.000 A²s

dV/dt critical: 1000V/µs

SCCR: 100KA 600V UL508 conformant

**Thermic Dissipation:**

GPC models dissipate thermic power based on load current:

$P_{dissipation} = I_{load\_Arms} * 1.3V$  (W)

For models with integrated fuse, also consider dissipated power at rated current shown on the fuse table.

**LED**

N. 8 LEDs indicator:

(All LEDs are configurable via SW, the Default configuration provides):

RUN (green) RUN state of the CPU ERROR (red) error

DI1 (yellow) DI1digital input state

DI2 (yellow) DI2digital input state

O1 (yellow) Out.1 main input state

O2 (yellow) Out.2 main input state

O3 (yellow) Out.3 main input state

BUTTON (yellow) State Key HB

**POWER SUPPLY**

**for models GPC 40-300A:**

**CPU Power supply**

24Vdc/±10% max.25VA

**Cooling Fan Power Supply (for each module PWR)**

24Vdc/±10%

Input @ 24 Vdc: max 500 mA

**POWER SUPPLY**

**for models GPC 400-600A :**

**GPC 1PH Power supply**

24Vdc/±10% max. 38 W

**GPC 2PH Power supply**

24Vdc/±10% max. 66 W

**GPC 3PH Power supply**

24Vdc/±10% max. 94 W

**Ambient conditions**

Working temperature: 0-50°C (see the derating curve)

Storage temperature:-20°C - +85°C

Max. relative humidity: 85% UR non-condensing

Max. installation altitude: 2000m above mean sea level

Installation requirements: Installation category II, pollution level 2, double isolation  
Max. temperature of air surrounding device 40°C for temperature > 40°C refer at derating curves

- Device type: "UL Open Type"

Installation: panel with screws

Dimensions: see dimensions and installation

**Weight**

models consider with integrated fuse:

GPC-1PH 40/60/100 A	3.2 Kg
GPC-2PH 40/60/100 A	5.2 Kg
GPC-3PH 40/60/100 A	7.2 Kg

GPC-1PH 150 A	3.3 Kg
GPC-2PH 150 A	5.4 Kg
GPC-3PH 150 A	7.5 Kg

GPC-1PH 200/250/300 A	3.6 Kg
GPC-2PH 200/250/300 A	6.0 Kg
GPC-3PH 200/250/300 A	8.4 Kg

GPC- 1PH 400 A	8 Kg
GPC- 2PH 400 A	15,5 Kg
GPC- 3PH 400 A	22,5 Kg

GPC- 1PH 500/600 A	11 Kg
GPC- 2PH 500/600 A	21 Kg
GPC- 3PH 500/600 A	31 Kg

# ELECTRICAL CONNECTIONS for models GPC 40-300A





## POWER CONNECTIONS

### RECOMMENDED WIRE GAUGES

GPC CURRENT LEVEL	TERMINAL	WIRE GAUGE	TERMINAL TYPE	TIGHTENING / TOOL TORQUE
40 A	1/L1, 2/T1	10 mm <sup>2</sup> 7 AWG	Wire stripped for 25 mm or with crimped pre-insulated terminal tube CEMBRE PKC1018	5 Nm / Flat-head screwdriver tip 1 x 5.5 mm
60 A	1/L1, 2/T1	16 mm <sup>2</sup> 5 AWG	Wire stripped for 25 mm or with crimped pre-insulated terminal tube CEMBRE PKC1618	5 Nm / Flat-head screwdriver tip 1 x 5.5 mm
100 A	1/L1, 2/T1,	35 mm <sup>2</sup> 2 AWG	Wire stripped for 25 mm or with crimped pre-insulated terminal tube CEMBRE PKC35025	5 Nm / Flat-head screwdriver tip 1 x 5.5 mm
150 A	1/L1, 2/T1	70 mm <sup>2</sup> 2/0 AWG	Wire stripped for 25 mm or with crimped pre-insulated terminal tube CEMBRE PKC70022	6 Nm / hex head wrench N. 6
200 A	1/L1, 2/T1	95 mm <sup>2</sup> 4/0 AWG	Wire stripped for 25 mm or with crimped pre-insulated terminal tube CEMBRE PKC95025	6 Nm / hex head wrench N. 6
250 A	1/L1, 2/T1	120 mm <sup>2</sup> 250 Kcmil	Wire stripped for 25 mm	6 Nm / hex head wrench N. 6
300 A	1/L1, 2/T1	185 mm <sup>2</sup> 350 Kcmil	Wire stripped for 25 mm	6 Nm / hex head wrench N. 6
---	3/L2 (Ref. Vline) 4/T2 (Ref. Vload)	0.25 ...2.5 mm <sup>2</sup> 23...14 AWG	Wire stripped for 8 mm or with tag terminal	0.5 ...0.6 Nm / Flat-head screwdriver tip 0.6 x 3.5 mm

**Note:** Cables must be copper "Stranded Wire" or "Compact-Stranded Wire" type with maximum operating temperature 60/75°C

### SIGNAL CABLES:

<b>J1: Outputs</b> <b>J2, J7: Power supply 24V</b> <b>J5, J6: Control inputs</b>		0,2 - 2,5mm <sup>2</sup>	24 - 14AWG
		0,25 - 2,5mm <sup>2</sup>	23 - 14AWG
<b>J3: Digital inputs</b> <b>J4: Inputs mV / TC AUX</b>		0,14 - 0,5mm <sup>2</sup>	28 - 20AWG
		0,25 - 0,5mm <sup>2</sup>	23 - 20AWG

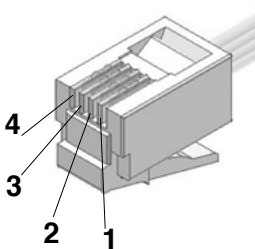
<b>J8, J9: SERIAL RS 485</b>	<b>Connector RJ10 4-4 pin</b> 	Nr. Pin	Name	Description	<b>Note</b> (**) Connect the GND signal among Modbus devices with a line distance > 100 m
		1	GND1 (**)		
2	Tx/Rx+		Data reception/transmission (A+)		
3	Tx/Rx-		Data reception/transmission (B-)		
4	+V (reserved)				

**Cable type:** flat telephone cable for pin 4-4 conductor 28AWG

# ELECTRICAL CONNECTIONS for models GPC 400-600A



## POWER CONNECTIONS

### RECOMMENDED WIRE GAUGES

GPC CURRENT LEVEL	TERMINAL	TYPE CABLE / SECTION TYPE RAIL / SECTION	TERMINAL TYPE CABLE / RAIL	TIGHTENING / TOOL TORQUE
400 A	1/L1, 2/T1	Single cable - 300 mm <sup>2</sup> (600Kcmil)	Wire crimped at terminal tube Cembre A60-M12	N. 1 Bolt M12x25mm UNI 5739 hex head wrench n. 18 Pair: 50 Nm
400 A	1/L1, 2/T1	Double cable - 2 x 95 mm <sup>2</sup> (3/0 AWG)	Wire crimped at terminal tube Cembre A19-M10	N. 2 Bolts M10x25mm UNI 5739 hex head wrench n. 17 Pair: 40 Nm
400 A	1/L1, 2/T1	Double cable - 2 x 95 mm <sup>2</sup> (3/0 AWG)	Wire stripped for 30mm inserted in ILSCO AU-350 lug (Accessory)	N. 1 Bolt M12x25mm UNI 5739 hex head wrench n. 18 Pair: 50 Nm (*) see note
400 A	1/L1, 2/T1	Copper rail (W= width, H = height) W = 40 32 24 mm H = 2 2 3 mm	Insulated copper rail with terminal non-insulated for L= 60-65mm max	N. 1 Bolt M12x25mm UNI 5739 hex head wrench n. 18 Pair: 50 Nm
400 A	PE	Cable 95 mm <sup>2</sup> (3/0 AWG)	Wire crimped at terminal tube Cembre A19-M10	N. 1 Bolt M10x20mm UNI 5739 hex head wrench n. 17 Pair: 40 Nm
500 A	1/L1, 2/T1	Double cable - 2 x 120 mm <sup>2</sup> (250 Kcmil)"	Wire crimped at terminal tube Cembre A24-M10	N. 2 Bolts M10x25 mm UNI 5739 hex head wrench n. 17 Pair: 40 Nm
500 A	1/L1, 2/T1	Double cable - 2 x 120 mm <sup>2</sup> (250 Kcmil)"	Wire stripped for 30mm inserted in ILSCO AU-350 lug (Accessory)	N.1 Bolt M12x25 mm UNI 5739 hex head wrench n. 18 Pair: 50 Nm (*)
500 A	1/L1, 2/T1	Copper rail (W= width, H = height) W = 40 32 24 mm H = 3 4 5 mm	Insulated copper rail with terminal non-insulated for L= 60-65 mm max	N. 1 Bolt M12x25 mm UNI 5739 hex head wrench n. 18 Pair: 50 Nm
500 A	PE	Cable 120 mm <sup>2</sup> (250 Kcmil)	Wire crimped at terminal tube Cembre A24-M10	N. 1 Bolt M10x20 mm UNI 5739 Chiave esagonale n. 17 Pair: 40 Nm
600 A	1/L1, 2/T1	Double cable - 2 x 185mm <sup>2</sup> (350 Kcmil)	Wire crimped at terminal tube Cembre A37-M10	N. 2 Bolts M10x25mm UNI 5739 hex head wrench n. 17 Pair: 40 Nm
600 A	1/L1, 2/T1	Double cable - 2 x 185mm <sup>2</sup> (350 Kcmil)	Wire stripped for 30mm inserted in ILSCO AU-350 lug (Accessory)	N.1 Bolt M12x25mm UNI 5739 hex head wrench n. 18 Pair: 50 Nm (*) see note
600 A	1/L1, 2/T1	Copper rail (W= width, H = height) W = 50 40 32 mm H = 4 4 5 mm	Insulated copper rail with terminal non-insulated for L= 60-65mm max	N.1 Bolt M12x25mm UNI 5739 hex head wrench n. 18 Pair: 50 Nm
600 A	PE	Cable 185mm <sup>2</sup> (350 Kcmil)	Wire crimped at terminal tube Cembre A37-M10	N. 1 Bolt M10x20mm UNI 5739 hex head wrench n. 17 Pair: 40 Nm
400 / 500 / 600 A	J6, J7	0.25 ... 2.5mm <sup>2</sup> cable 23 ...14 AWG	Cable peeled for 8mm or with a tag terminal	0.6 ...0.6 Nm / 0.6 x 3.5mm slotted screwdriver

(\*) NOTE: Wires on the ILSCO accessory must be tightened with a hex head wrench n. 8. Torque: 30 Nm.

### SIGNAL CABLES:

<b>J1: Auxiliary outputs</b> <b>J2: Relay output</b> <b>J3: Supply 24V and digital inputs</b> <b>J4: Analog control inputs</b> <b>J5: CT external inputs</b> <b>J6: V-line connector</b> <b>J7: V-load connector</b>		0,2 - 2,5mm <sup>2</sup>	24 - 14AWG
		0,25 - 2,5mm <sup>2</sup>	23 - 14AWG

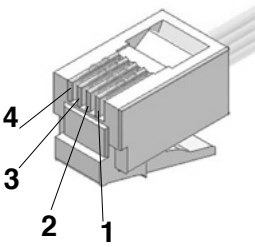
Connector RJ10 4-4 pin	Nr. Pin	Name	Description	Note
<b>J8, J9: SERIAL RS 485 (PORT1)</b> 	1	GND1 (**)		(**) Connect the GND signal among Modbus devices with a line distance > 100 m
	2	Tx/Rx+	Data reception/transmission (A+)	
	3	Tx/Rx-	Data reception/transmission (B-)	
	4	+V (reserved)		

Cable type: flat telephone cable for pin 4-4 conductor 28AWG

# ORDER CODE

GPC -

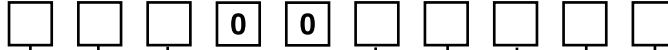

Model	
Module Mono-Phase (Master)	<b>1PH</b>
Module Dual-Phase (Master + n. 1 expansion)	<b>2PH</b>
Module Three-phase (Master + n. 2 Expansions)	<b>3PH</b>

Nominal Current	
40 Ampere	40
60 Ampere	60
100 Ampere	100
150 Ampere	150
200 Ampere	200
250 Ampere	250
300 Ampere	300
400 Ampere	400
500 Ampere	500
600 Ampere	600

Nominal Voltage	
480Vac (*)	480
600Vac (*)	600
690Vac	690

Control options	
Absent	0
Current limit	1
Current limit and feedback V,I,P	2
Current limit and feedback V,I,P + Vload input	3
Current limit and feedback V,I,P + Vload input + + 3 TA external input (**)	4

FIELDBUS Port 2 opz.	
0	Absent
M	Modbus RTU
P	Profibus DP
C	CANopen
E	Ethernet Modbus TCP
E6	Profinet
E7	EtherCAT
E8	Ethernet IP

Fuses	
0	Absent
1	Self-contained

Diagnostics and Alarm Options	
0	Absent
1	Partial and total load break alarm (HB) "+ Diagnostic alarms

Auxiliary Output opz.	
0	Absent
R	4 Relays
D	4 Digital outputs
W	3 analogue output 12 bit, 0-10V 4-20mA retransmission

**NOTE**

(\*) Option not available for models with Nominal Current  $\geq 400A$

(\*\*) Option not available for models for 690Vac models with Nominal Current  $\leq 300A$

## ACCESSORIES

### CONFIGURATION KIT

#### KIT PC USB / RS485 o TTL



Configuration/supervision kit for GPC by means of PC with USB (Windows environment). Lets you read or write all of the parameters of a single GPC. A single software for all models

- Easy and rapid configuration
- Saving and management of parameter recipes
- On-line trend and saving of historical data

Component Kit:

- Connection cable PC USB <----> GPC RS485 port
- Serial line converter
- CD SW GF Express installation

#### ORDERING CODE

GF\_eXK-2-0-0

Cod. F049095



The human/machine interface (HMI) is simple, intuitive, and very practical thanks to the optional GPC – OP programming keyboard.

Lets you read or write all of the parameters of a single GPC-M module.

Connected with 9-pin D-SUB connector and housed in the front panel of the GPC-M by means of a magnetic plate.

- Alphameric display: 5 lines x 21 characters.
- Keys to display variable and set parameters.
- Magnetic housing

#### ORDERING CODE

GFW/GPC-OP

Cod. F068952



Kit for 400/600A wiring with stripped wires (with this kit, wires with crimped terminal tube are not required), consisting of:

- 2 ILSCO lugs
- 2 M12x25 bolts
- 2 Belleville washers
- 2 IP20 protection grids for GPC400/600

#### ORDERING CODE

ILSCO Lug Kit

Cod. F067432



# FUSES

Model	EXTRARAPID FUSES			
	Size I <sup>2</sup> t	Code Format	Model Code	Power Dissipated @ In
GPC 40	80A 2500A <sup>2</sup> s	FUS-080S	DN000UB69V80 338933	5 W
GPC 60	125A 8900A <sup>2</sup> s	FUS-125S	DN000UB69V125 338934	6 W
GPC 100	160A 16000A <sup>2</sup> s	FUS-160S	DN000UB69V160 338935	12 W
GPC 150	200A 31500A <sup>2</sup> s	FUS-200S	DN000UB69V200 338930	19 W
GPC200/250/300 480/600V	450A 196000A <sup>2</sup> s	FUS-450S	DN00UB60V450L 338932	17 W
GPC 200/250/300 690V	400A 150000A <sup>2</sup> s	FUS-400S	DN00UB69V400L 338936	20 W
GPC 400	1000A 970000A <sup>2</sup> s	FUS-1000	PC33UD69V1000TF 338160	40 W
GPC 500	1000A 970000A <sup>2</sup> s	FUS-1000	PC33UD69V1000TF 338160	50 W
GPC 600	1000A 970000A <sup>2</sup> s	FUS-1000	PC33UD69V1000TF 338160	60 W

SCCR RMS SYM 100KA / 600V		UL508 SCCR FUSES TABLE			
Model	Configuration	"Short circuit current [Arms]"	"Max fuse size [A]"	Fuse Class	"Max Voltage [VAC]"
GPC 400	1PH or 2PH or 3PH	100.000	400	J	600
GPC 500	1PH or 2PH or 3PH	100.000	600	J	600
GPC 600	1PH or 2PH or 3PH	100.000	600	J	600

The fuses on the above table are representative of all the fuses of the same class with lower current ratings

## • WARNINGS



**WARNING:** this symbol indicates danger.

**Before installation, please read the following advices:**

- Follow the indications of the manual scrupulously when making the connections to the product
- Use a cable that is suitable for the ratings of voltage and current indicated in the technical specifications.
- If the instrument is used in applications where there is risk of injury to persons and damage to machines or materials, it is essential that it is used with an auxiliary alarm device.  
It is advisable to verify frequently that the alarm device is functional even during the normal operation of the equipment.
- The product must not be used in environments where there could be the presence of dangerous atmospheres (inflammable or explosive).
- During continuous operation, the heatsink may reach 100°C and remain at a high temperature due to thermal inertia even after the device is switched off. Therefore, do not touch the heat sink or the electrical wires.
- Do not operate on the power circuit unless the main supply is disconnected.
- Do not open the cover if device is "on"!

**Installation:**

- Connect the device to the ground using the proper ground terminal.
- The power supply wiring must be kept separate from that of inputs and outputs of the instrument; always check that the supply voltage corresponds to that indicated on the instrument cover.
- Delete this line entirely.
- Keep away from dust, humidity, corrosive gases and heat sources.

**Maintenance:** Check the correct operation of the cooling fans at regular intervals; clean the ventilation air filters of the installation at regular intervals.

- Repairs must be performed only by specialized or appropriately trained personnel. Cut off power to the device before accessing internal parts.
- Do not clean the box with solvents derived from hydrocarbons (trichloroethylene, gasoline, etc.). Using such solvents will compromise the mechanical reliability of the device.

To clean external plastic parts, use a clean cloth wet with ethyl alcohol or water.

**Technical service:** GEFRAN has a technical service department. Defects caused by use not conforming to the instructions are excluded from the warranty

GEFRAN spa reserves the right to make any kind of design or functional modification at any moment without prior notice

<b>CE</b>	This device conforms to European Union Directive 2014/30/EU e 2014/35/EU with reference to generic standards: <b>EN 60947-4-3</b> (product)
<b>UL</b>	Conformity C/UL/US file no. <b>E243386 vol. 1 sez. 5</b>
<b>SCCR RMS SYM</b> 100KA / 600V	Short Circuit Current Rating 100KA / 600V according to UL 508